

Transformer Specifications	
PRIMARY VOLTAGE(S)	400/480/600V
SECONDARY VOLTAGE(S)	120V@250VA, 24V@50VA
RATED V. A.	300
RATED FREQUENCY	50/60
INSULATION CLASS	105
AGENCY APPROVALS	UL, RoHS, CE
ESTIMATED WEIGHT	12.6 LBS

TEST REQUIREMENTS					
WINDING	H1-H2	H1-H3	H1-H4	X1-X2	X3-X4
O. C. VOLTS	400	480	600	126	26.3
LOAD VOLTS	400	480	600	120	24
P. L. AMPS	0.75	0.625	0.5	2.08	2.08
HI-POT (for 2s)	3000V	3000V	3000V	1800V	1800V

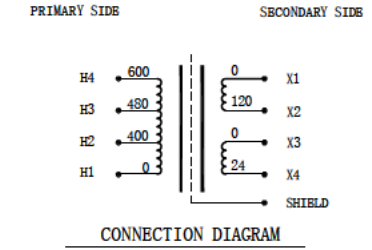
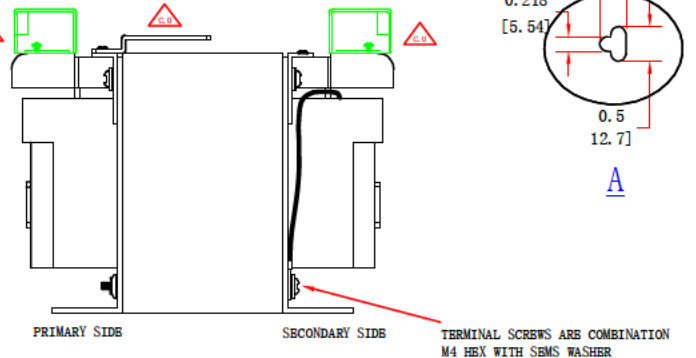
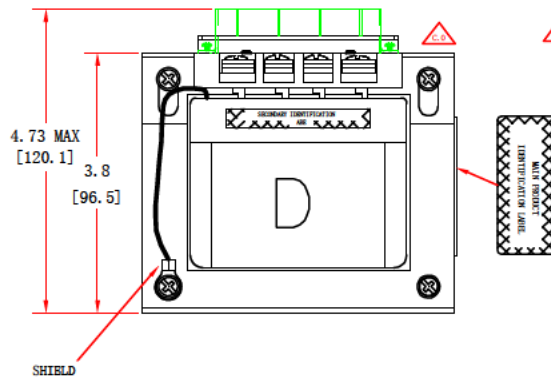

NOTE:
1. ALL MEASUREMENTS IN INCHES (MM).

公差等级	IT13
单位用量	1
比例	
材质	

MAIN PRODUCT IDENTIFICATION LABEL

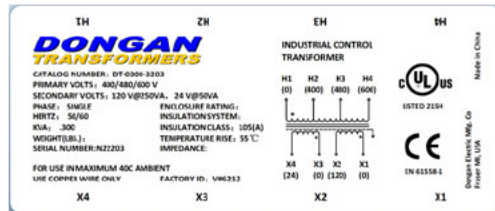

PRIMARY IDENTIFICATION LABEL

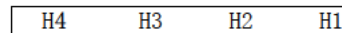

SECONDARY IDENTIFICATION LABEL

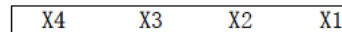

DONGAN ELECTRIC MFG CO

公差等级	IT13	颜色		<input type="checkbox"/> 草图	<input type="checkbox"/> 样品图纸	<input checked="" type="checkbox"/> 产品图纸
单位用量	1	单位	in/[MM]	DT-0300-3203 控制变压器		
比例		日期	2022/11/02	画图	LK	设计 HSG
材质		版次	REV C.0	图号	XW22050601C	文件位置

此表保存至停产

表单编号: F-011-A.1